

Series "FC" Cabinet

Function

To protect electronic components including controls and instruments.

Features

Aluminum enclosures for protection from all forms of outdoor natural elements including rain, sleet and snow, also seepage and splash.

Specifications

Enclosure

1. Completely fabricated from .125"-thick type 5052-H32. Vinyl coated, mill-finished aluminum utilizing intermittently welded construction.
2. "C" channels on rear to simplify panel mounting.
3. All internal and external hardware utilize non-corrosive material

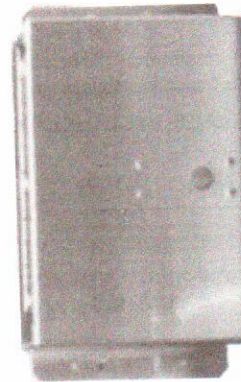

Door

1. Main door lock – industrial, standard pin tumbler lock with #2 key.
2. Closed-cell neoprene door seal gasket.
3. Heavy gauge aluminum hinge utilizing a non-removable stainless steel hinge pin.

Series "FC" Cabinet

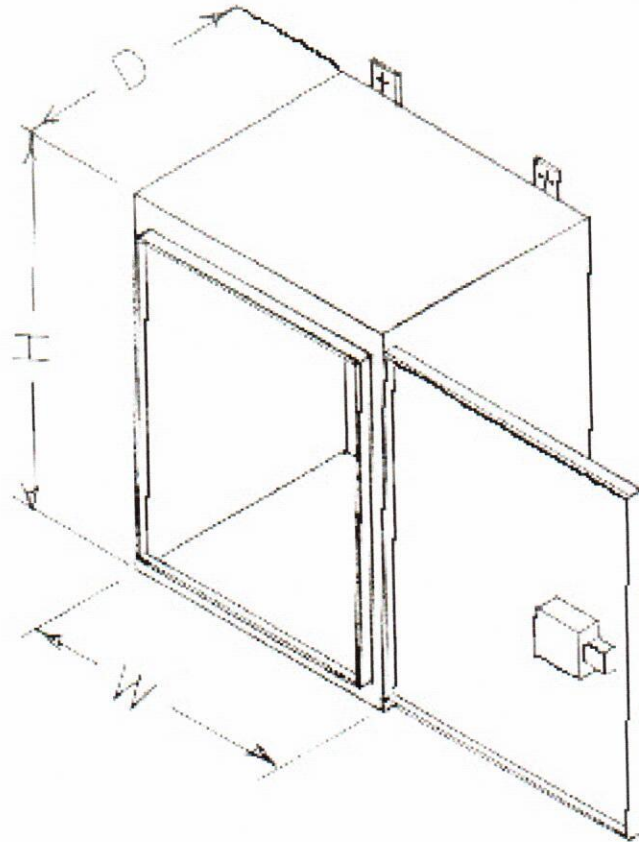

Options

1. Available with height, width and depth variations in one-inch increments.
2. Optional Shelf
3. Special finish per customer requirements.

MODEL	H x W x D
FC100	14 x 10 x 7
FC101	14 x 11 x 11
FC102	14 x 14 x 7
FC103	16 x 12 x 8
FC104	16 x 14 x 12
FC105	22 x 15 x
FC106	16 x 14 x 10